

PART NUMBER	THREAD (MIL-S-8879)	A MAX	B REF	C +/- .002	D MIN	E REF	H MAX	J +/- .005	K +.005 - .000	V REF	APPROX WT LBS/100
MS21073-04	.1120-32 UNJC-3B	.448	.220	.287	-	.125	.130	.203	.098	.025	.09
MS21073-06	.1280-32 UNJC-3B	.457	.220	.308	-	.125	.145	.218	.098	.032	.13
MS21073-08	.1640-32 UNJC-3B	.497	.220	.331	.168	.125	.215	.234	.098	.032	.17
MS21073-3	.1900-32 UNJF-3B	.526	.220	.354	.194	.156	.220	.250	.098	.032	.22
MS21073-4	.2500-28 UNJF-3B	.603	.220	.398	.254	.203	.281	.281	.098	.040	.37
MS21073-5	.3125-24 UNJF-3B	.757	.270	.508	.317	.250	.328	.359	.130	.050	.63

MATERIAL: Carbon steel per AMS 5085 (UNS G10500).

FINISH: Cadmium plate per QQ-P-416, Type II Class 2 and Kaylube molybdenum disulfide dry film lubricant per MIL-L-460010

PERFORMANCE: MIL-N-25027

MS 21073 NUTPLATE

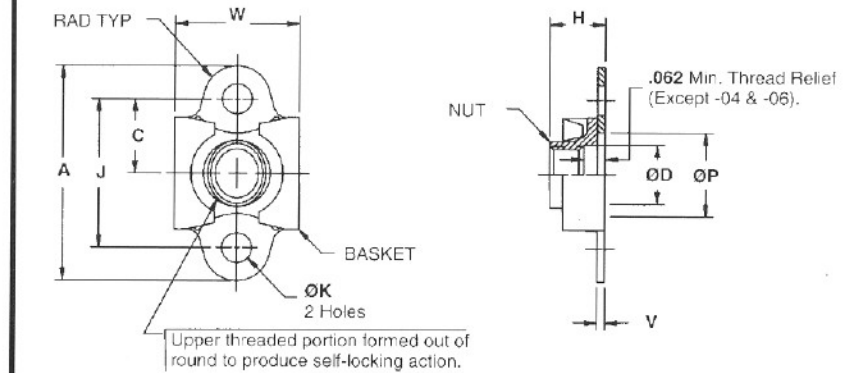

PART NUMBER	THREAD (MIL-S-8879)	A MAX	C +/- .010	D MIN	H MAX	J +/- .004	K +.005 - .000	P REF	V REF	W MAX	APPROX WT LBS/100
MS21075-04	.1120-40 UNJC-3B	.651	.208	-	.153	.408	.098	.164	.020	.315	25
MS21075-06	.1380-32 UNJC-3B	.682	.223	-	.171	.439	.098	.190	.020	.357	25
MS21075-08	.1640-32 UNJC-3B	.707	.239	.168	.250	.470	.098	.214	.025	.367	28
MS21075-3	.1900-32 UNJF-3B	.739	.255	.194	.250	.502	.098	.240	.025	.416	.30
MS21075-4	.2500-28 UNJF-3B	.801	.286	.254	.281	.564	.098	.300	.032	.500	.49
MS21075-5	.3125-24 UNJF-3B	1.010	.364	.317	.328	.720	.130	.375	.032	.581	-

MATERIAL: C1050 carbon steel per AMS 5085 (UNS G10500). Heat treat - Rc 49, maxium.

FINISH: Cadmium plate per QQ-P-416, Type II Class 2 and Kaylube molybdenum disulfide dry film lubricant per MIL-L-460010

FLOATABILITY: .030 min. radially from center

MS 21075 NUTPLATE