

# Locking Nuts to DIN 934 / 439

**Normal Form**  
DIN 934 / ISO 4032

**Narrow Form**  
DIN 439 / 936

Locking Nuts with right  
or left hand thread.  
Steel zinc plated or  
stainless Steel A2

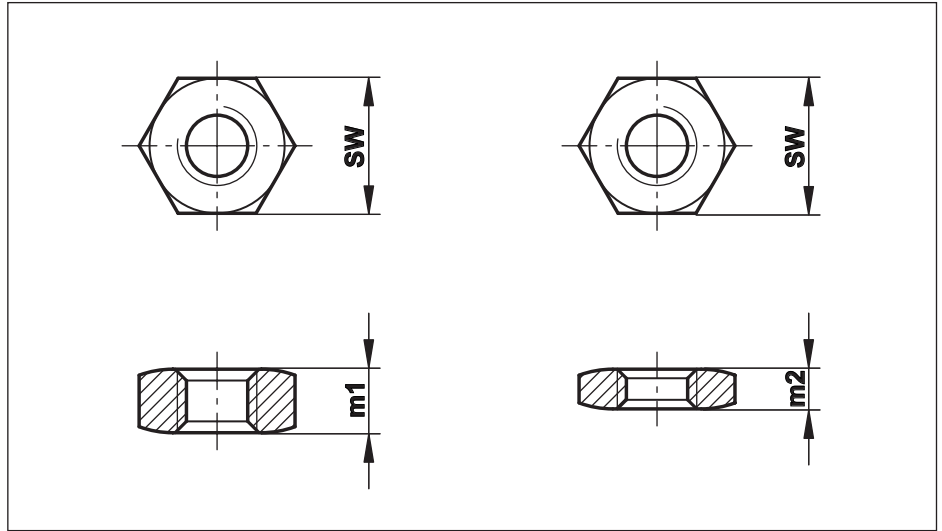

Nominal Size	Standard Thread Pitch	SW	Thread Pitch M ...											ISO 4032/DIN934		ISO 4036/DIN439			
			x0,4	x0,5	x0,7	x0,8	x1,0	x1,25	x1,5	x1,75	x2,0	x2,5	x3,0	x4,0	m <sub>1</sub>	Weight g	m <sub>2</sub>	Weight g	
M 3	(M 3x0,5)	5,5		X												2,4	0,4	1,8	0,3
M 4	(M 4x0,7)	7,0			X											3,2	0,8	2,2	0,6
M 5	(M 5x0,8)	8,0				X										4,0	1,2	2,7	0,8
M 6	(M 6x1)	10,0					X									5,0	2,4	3,2	1,5
M 8	(M 8x1,25)	13,0					X	X								6,5	5,1	4,0	3,1
M 10	(M10x1,5)	17,0					X	X	X							8,0	11,1	5,0	6,9
M 12	(M 12x1,75)	19,0						X	X	X						10,0	16,3	6,0	9,8
M 14	(M 14x2)	22,0									X					11,0	24,0	7,0	15,0
M 16	(M 16x2)	24,0							X		X					13,0	32,0	8,0	19,5
M 18	(M 18x2,5)	27,0							X							15,0	47,0	9,0	28,0
M 20	(M 20x2,5)	30,0							X			X				16,0	61,0	10,0	38,0
M 22	(M22x2,5)	32,0							X							18,0	75,0	11,0	46,0
M 24	(M 24x3)	36,0									X					19,0	104,0	12,0	66,0
M 27	(M 27x3)	41,0										X				22,0	158,0	13,5	96,0
M 30	(M 30x3,5)	46,0										X				24,0	219,0	15,0	137,0
M 36	(M 36x4)	55,0										X		X		29,0	370,0	18,0	230,0
M 39	(M 39x4)	60,0												X		31,0	470,0	19,5	300,0
M 42	(M 42x4,5)	65,0										X		X		34,0	610,0	21,0	380,0
M 45	(M 45x4,5)	70,0												X		36,0	750,0	22,5	470,0
M 48	(M 48x5)	75,0										X				38,0	910,0	24,0	580,0
M 52	(M 52x5)	80,0												X		42,0	1130,0	26,0	700,0
M 56	(M 56x5,5)	85,0													X	45,0	1350,0	28,0	840,0
M 64	(M 64x6)	95,0													X	51,0	1850,0	32,0	1160,0

X) available ex stock, Standard Form only with standard thread in stock

**Materials:** Steel zinc plated, strength grade: 04 or better  
A2 is equivalent to stainless steel 1.4301, Aisi 304 and 1.4303, Aisi 305 or alternative material

**Thread:** Right hand or left hand threads

**Remarks:** Across-flats dimension SW, Weight, Width m1/m2 and Chamfer can differ from the table above and the DIN, because of different manufacturing methods  
**Locking Nuts DIN 439** according to **ISO 4036** (without chamfer) or **ISO 4035** (with chamfer).  
**Locking Nuts DIN 439 Fine Thread** according to **ISO 8675** (with chamfer).

**Ordering:** e.g. **Locking Nut M 10 Left Hand** (Normal Form with standard thread) in stainless steel A2:

**Details:** **Locking Nut DIN 934-M10-A2-Left Hand**  
e.g. **Locking Nut M 39x3 Right Hand** (Narrow Form) in Steel, zinc plated:  
**Locking Nut DIN 439-M39x3-04**