

# Rod Ends Series K - Stainless

## Series GARS

Rod Ends with male thread made from stainless steel, regreasable through grease nipple in housing

For use in corrosive environments

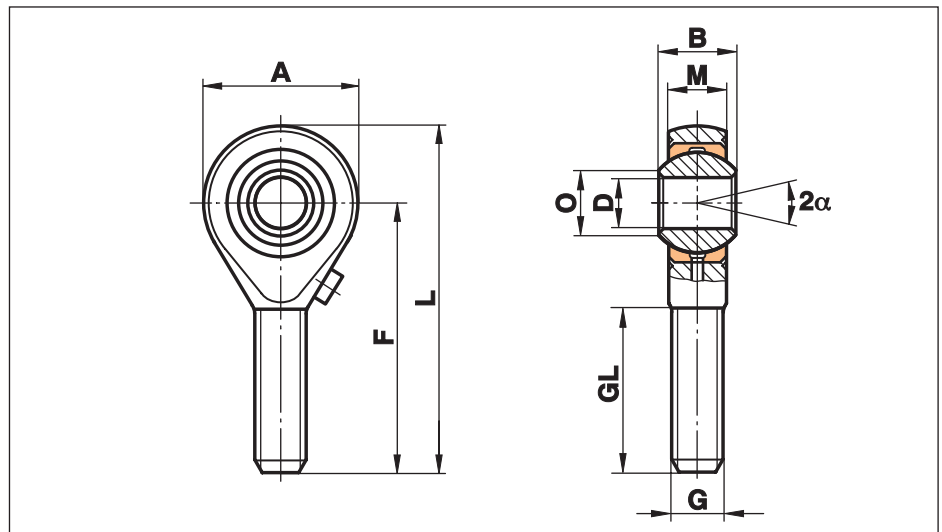

Size (D)	B	M	A	F	L	O	G	GL	Static load C <sub>0</sub> kN	Dynamic load C kN	Limiting speed rev/min	Weight g
3 <sup>1)</sup>	6	4,50	14	26	33	5,1	M 3	15	7,0	1,8		6
5 <sup>1)</sup>	8	6,00	18	33	42	7,7	M 5	20	6,2	3,3		13
6	9	6,75	20	36	46	8,9	M 6	22	8,8	4,3	1500	20
8	12	9,00	24	42	54	10,4	M 8	25	16,1	7,1	1200	33
10	14	10,50	28	48	62	12,9	M 10	29	25,5	10,0	1000	56
12	16	12,00	32	54	70	15,4	M 12	33	34,5	13,5	860	87
14	19	13,50	36	60	78	16,8	M 14	38	39,5	17,0	750	129
16	21	15,00	42	66	87	19,3	M 16	40	60,5	21,5	660	189
18	23	16,50	46	72	95	21,8	M 18x1,5	44	73,0	26,0	600	267
20	25	18,00	50	78	103	24,3	M 20x1,5	47	83,0	31,5	540	348
22	28	20,00	54	84	111	25,8	M 22x1,5	51	100,0	38,0	500	443
25	31	22,00	60	94	124	29,6	M 24x2	58	118,0	47,0	440	600
30	37	25,00	70	110	145	34,8	M 30x2	71	155,0	64,0	370	1030
35	43	28,00	80	125	165	37,7	M 36x2	73	191,0	80,0	330	1600
40	49	35,00	90	142	187	44,2	M 42x2	78	235,0	116,0	290	2570

## Materials:

**Housing:** Stainless steel to 1.4057, Aisi 431, forged, polished  
size 40 made from stainless steel to 1.4057, Aisi 431, turned

**Insert:** Special high strength bronze to CuSn8

**Ball:** Bearing steel to 100Cr6, Aisi 52100, hardened, ground, polished, hard chrome plated

**On request:** The ball can be made from stainless steel to 1.4034, Aisi 420C, hardened, ground, polished

**On request:** The insert can be made to stainless steel 1.4301, Aisi 304, or 17-4PH (1.4542) etc.

This series is also available sealed (see page 38) or with threaded bolt (see page 39).

<sup>1)</sup> without lubrication fitting