

Rod Ends Series K - Steel on Steel

Series GIO

Rod Ends with female thread made from free-cutting or heat-treated steel, zinc plated without the insert, running surface steel on steel

High axial load in one direction only. To be used only with limited oscillating movements

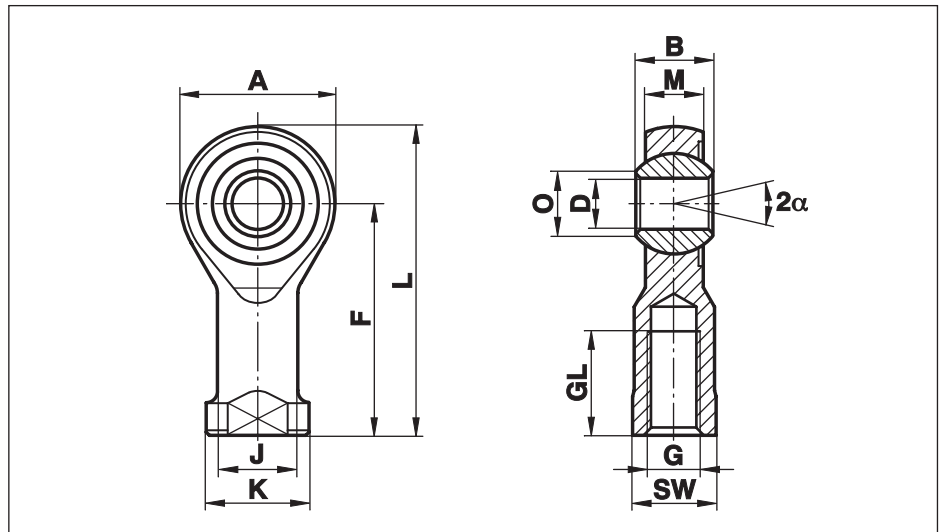

Size (D)	B	M	A	F	L	K	J	O	SW	G	GL	Static load C ₀ kN	Dynamic load C kN	Limiting speed rev/min	Weight g
5	8	6,00	18	27	36	11	9,0	7,7	9	M 5	10	12,0	2,2	not to be used for complete revolutions	18
6	9	6,75	20	30	40	13	10,0	8,9	11	M 6	12	14,3	2,8		27
8	12	9,00	24	36	48	16	12,5	10,4	13	M 8	16	21,7	4,6		46
10	14	10,50	28	43	57	19	15,0	12,9	17	M 10	20	27,8	6,5		76
12	16	12,00	32	50	66	22	17,5	15,4	19	M 12	22	35,0	8,5		115
14	19	13,50	36	57	75	25	20,0	16,8	22	M 14	25	32,5	11,0		170
16	21	15,00	42	64	85	27	22,0	19,3	22	M 16	28	46,0	14,0	230	
20	25	18,00	50	77	102	34	27,5	24,3	32	M 20x1,5	33	63,0	20,0	415	

Materials:

Housing: up to size 12 turned, from free-cutting steel to 9SMnPb28K, 12L13
from size 14 forged, from heat-treated steel to C22, M1023

Ball: Bearing steel to 100Cr6, Aisi 52100, hardened, ground, polished

Cetop connections see page 40.

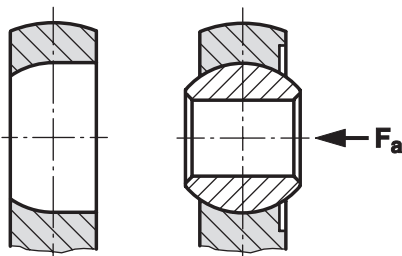

The base in the steel housing is cylindrically turned from one side and, starting from the centre line, it runs to suit the ball's contour (see drawing). Hence a high axial load towards the turned radius is possible.