

Rod Ends Series K - Stainless

Series GIRS

Rod Ends with female thread made from stainless steel, regreasable through grease nipple in housing

For use in corrosive environments

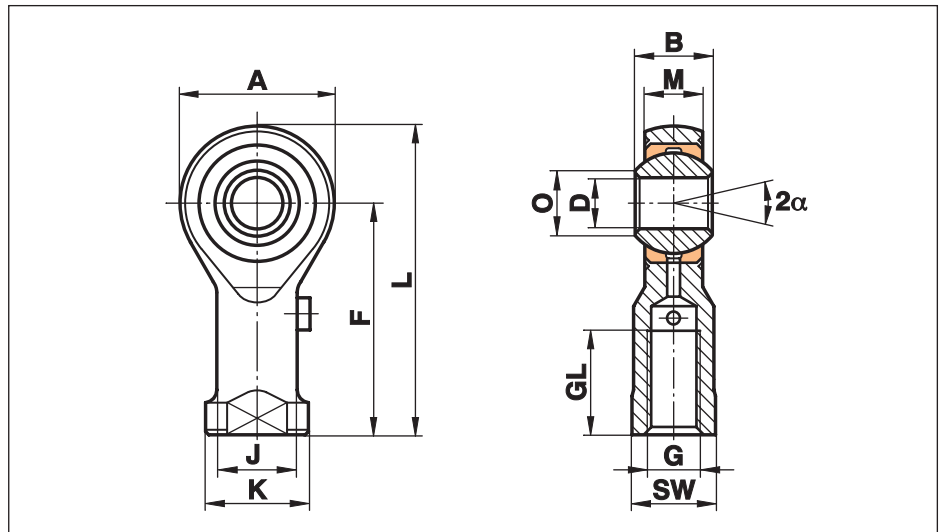

Size (D)	B	M	A	F	L	K	J	O	SW	G	GL	Static load C ₀ kN	Dynamic load C kN	Limiting speed rev/min	Weight g
3 ¹⁾	6	4,50	14	21	27	6,5	5,0	5,1	5,5	M 3	10	8,0	1,8		6
5	8	6,00	18	27	36	11,0	9,0	7,7	9,0	M 5	10	11,8	3,3	1200	18
6	9	6,75	20	30	40	13,0	10,0	8,9	11,0	M 6	12	13,1	4,3	1500	27
8	12	9,00	24	36	48	16,0	12,5	10,4	13,0	M 8	16	20,7	7,1	1200	46
10	14	10,50	28	43	57	19,0	15,0	12,9	17,0	M 10	20	28,3	10,0	1000	76
12	16	12,00	32	50	66	22,0	17,5	15,4	19,0	M 12	22	34,5	13,5	860	115
14	19	13,50	36	57	75	25,0	20,0	16,8	22,0	M 14	25	39,5	17,0	750	170
16	21	15,00	42	64	85	27,0	22,0	19,3	22,0	M 16	28	60,5	21,5	660	230
18	23	16,50	46	71	94	31,0	25,0	21,8	27,0	M 18x1,5	32	73,0	26,0	600	320
20	25	18,00	50	77	102	34,0	27,5	24,3	32,0	M 20x1,5	33	83,0	31,5	540	415
22	28	20,00	54	84	111	37,0	30,0	25,8	32,0	M 22x1,5	37	100,0	38,0	500	540
25	31	22,00	60	94	124	42,0	33,5	29,6	36,0	M 24x2	42	118,0	47,1	440	750
30	37	25,00	70	110	145	51,0	40,0	34,8	41,0	M 30x2	51	155,0	64,0	370	1130
35	43	28,00	80	125	165	58,0	46,0	37,7	50,0	M 36x2	56	191,0	80,0	330	1600
40	49	35,00	90	142	187	69,0	57,0	44,2	60,0	M 42x2	60	235,0	116,0	290	2770

Materials:

Housing: Stainless steel to 1.4057, Aisi 431, forged, polished
size 40 made from stainless steel to 1.4057, Aisi 431, turned

Insert: Special high strength bronze to CuSn8

Ball: Bearing steel to 100Cr6, Aisi 52100, hardened, ground, polished, hard chrome plated

On request: The ball can be made from stainless steel to 1.4034, Aisi 420C, hardened, ground, polished

On request: The insert can be made to stainless steel 1.4301, Aisi 304, or 17-4PH (1.4542) etc.

This series is also available sealed (see page 38) or with threaded bolt (see page 39).

Cetop connections see page 40.

¹⁾ without lubrication fitting