

Rod Ends Series K - Stainless, Maintenance Free

Series GIRSW

Rod Ends with female thread made from stainless steel with PTFE liner, maintenance free

For use at high dynamic pressure and tension loads in corrosive environments

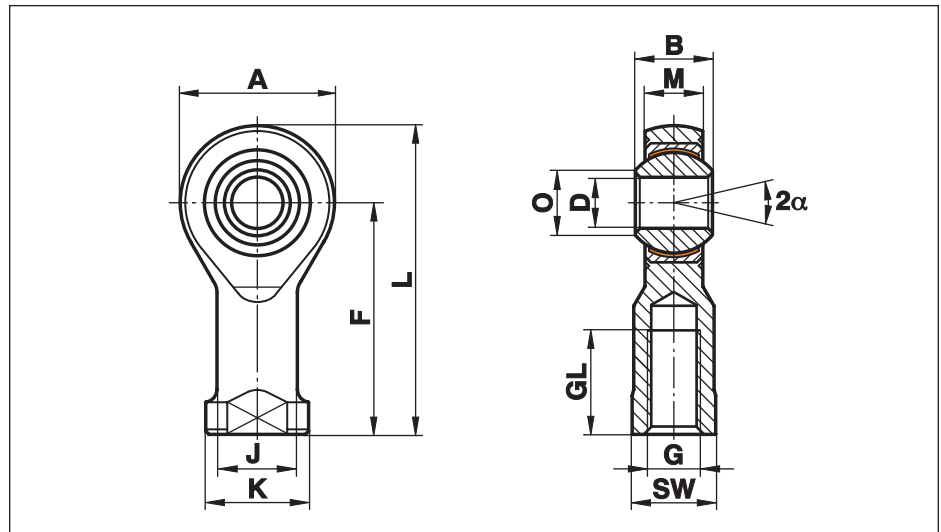

| Size (D) | B | M | A | F | L | K | J | O | SW | G | GL | Static load C ₀ kN | Dynamic load C kN | Limiting speed rev/min | Weight g |
|-----------------|----|-------|----|-----|-----|------|------|------|----|----------|----|-------------------------------|-------------------|------------------------|----------|
| 4 ¹⁾ | 7 | 5,25 | 14 | 24 | 31 | 9,5 | 7,8 | 6,5 | 8 | M 4 | 12 | 2,7 | 0,8 | — | 11 |
| 5 | 8 | 6,00 | 18 | 27 | 36 | 11,0 | 9,0 | 7,7 | 9 | M 5 | 10 | 11,8 | 7,5 | 600 | 18 |
| 6 | 9 | 6,75 | 20 | 30 | 40 | 13,0 | 10,0 | 8,9 | 11 | M 6 | 12 | 13,1 | 9,3 | 530 | 27 |
| 8 | 12 | 9,00 | 24 | 36 | 48 | 16,0 | 12,5 | 10,4 | 13 | M 8 | 16 | 20,7 | 16,7 | 420 | 46 |
| 10 | 14 | 10,50 | 28 | 43 | 57 | 19,0 | 15,0 | 12,9 | 17 | M 10 | 20 | 28,3 | 23,4 | 350 | 76 |
| 12 | 16 | 12,00 | 32 | 50 | 66 | 22,0 | 17,5 | 15,4 | 19 | M 12 | 22 | 34,5 | 32,0 | 300 | 115 |
| 14 | 19 | 13,50 | 36 | 57 | 75 | 25,0 | 20,0 | 16,8 | 22 | M 14 | 25 | 39,5 | 42,0 | 260 | 170 |
| 16 | 21 | 15,00 | 42 | 64 | 85 | 27,0 | 22,0 | 19,3 | 22 | M 16 | 28 | 60,5 | 52,5 | 230 | 230 |
| 18 | 23 | 16,50 | 46 | 71 | 94 | 31,0 | 25,0 | 21,8 | 27 | M 18x1,5 | 32 | 73,0 | 64,0 | 210 | 320 |
| 20 | 25 | 18,00 | 50 | 77 | 102 | 34,0 | 27,5 | 24,3 | 32 | M 20x1,5 | 33 | 83,0 | 78,0 | 190 | 415 |
| 22 | 28 | 20,00 | 54 | 84 | 111 | 37,0 | 30,0 | 25,8 | 32 | M 22x1,5 | 37 | 100,0 | 97,0 | 170 | 540 |
| 25 | 31 | 22,00 | 60 | 94 | 124 | 42,0 | 33,5 | 29,6 | 36 | M 24x2 | 42 | 118,0 | 122,0 | 150 | 750 |
| 30 | 37 | 25,00 | 70 | 110 | 145 | 50,0 | 40,0 | 34,8 | 41 | M 30x2 | 51 | 155,0 | 168,0 | 130 | 1130 |
| 35 | 43 | 28,00 | 80 | 125 | 165 | 58,0 | 46,0 | 37,7 | 50 | M 36x2 | 56 | 191,0 | 206,0 | 110 | 1600 |
| 40 | 49 | 35,00 | 90 | 142 | 187 | 69,0 | 57,0 | 44,2 | 60 | M 42x2 | 60 | 235,0 | 286,0 | 100 | 2770 |

only for short-term revolutions recommended

Materials:

Housing: Stainless steel to 1.4057, Aisi 431, forged, polished
size 40 turned from stainless steel to 1.4057, Aisi 431

Insert: Special high strength bronze to CuSn8 with PTFE liner bonded to the inner surface

Ball: Bearing steel to 100Cr6, Aisi 52100, hardened, ground, polished, hard chrome plated

On request: Insert: Stainless steel to 1.4571, Aisi 316Ti
Ball: Stainless steel to 1.4034, Aisi 420C hardened, ground, polished
or in stainless steel to 1.4401, Aisi 316 ground, polished

This series is also available sealed (see page 38) or with threaded bolt (see page 39).

Cetop connections see page 40.

¹⁾ Size 4 on request. Housing turned from stainless steel to 1.4305, Aisi 303