

# Hydraulic Rod Ends

## Series FMA...D

Rod Ends fastened by hexagon socket head cap screws to DIN 912-8.8. Spherical Plain Bearings, regreasable, fixed with snap rings

For use with double action Hydraulic Cylinders

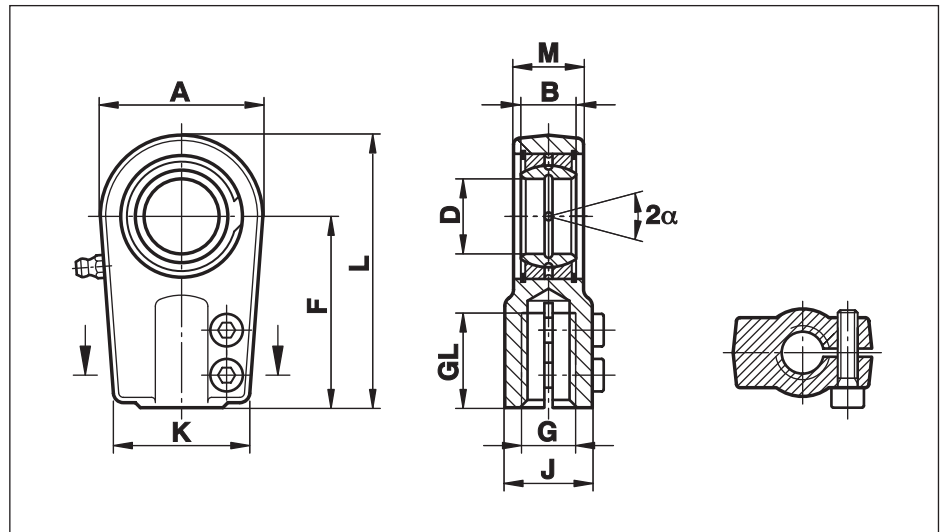

Size (D)	B	M	A	F	L	K	J	G	GL	Torque Nm	Static load C <sub>0</sub> kN	Dynamic load C kN	Pivoting angle α	Weight g
25	20	23	56	65	95	48	28	M 18x2	30	20	76	48	8	650
30	22	28	64	75	109	56	34	M 24x2	35	20	112	62	7	1000
35	25	30	78	90	132	70	44	M 30x2	45	40	180	80	7	1300
40	28	35	94	105	155	78	55	M 39x3	55	80	295	100	7	2400
50	35	40	116	135	198	88	70	M 50x3	75	80	445	156	7	4100
60	44	50	130	170	240	118	87	M 64x3	95	160	530	245	7	6500
70	49	55	154	195	278	138	105	M 80x3	110	160	720	315	6	9500
80	55	60	176	210	305	168	125	M 90x3	120	300	890	400	6	16000
90	60	65	206	250	363	180	150	M 100x3	140	300	1300	490	5	28000
100	70	70	230	275	400	188	170	M 110x4	150	300	1490	610	7	34000

### Materials:

**Housing:** Nodular cast iron GS400

**Bearing:** Steel on steel bearing GE...E, requiring lubrication

**Greasing:** size 25 without lubrication fitting, but fitted with grease hole in housing from size 30 fitted with hydraulic grease nipples to DIN 71412

**On request:** with left hand thread (FMAL...D)