

Combined bearings RAX 400 – RAX 500

Machine-tool
quality combined
bearings
RAXN 400,
RAXN 500
series

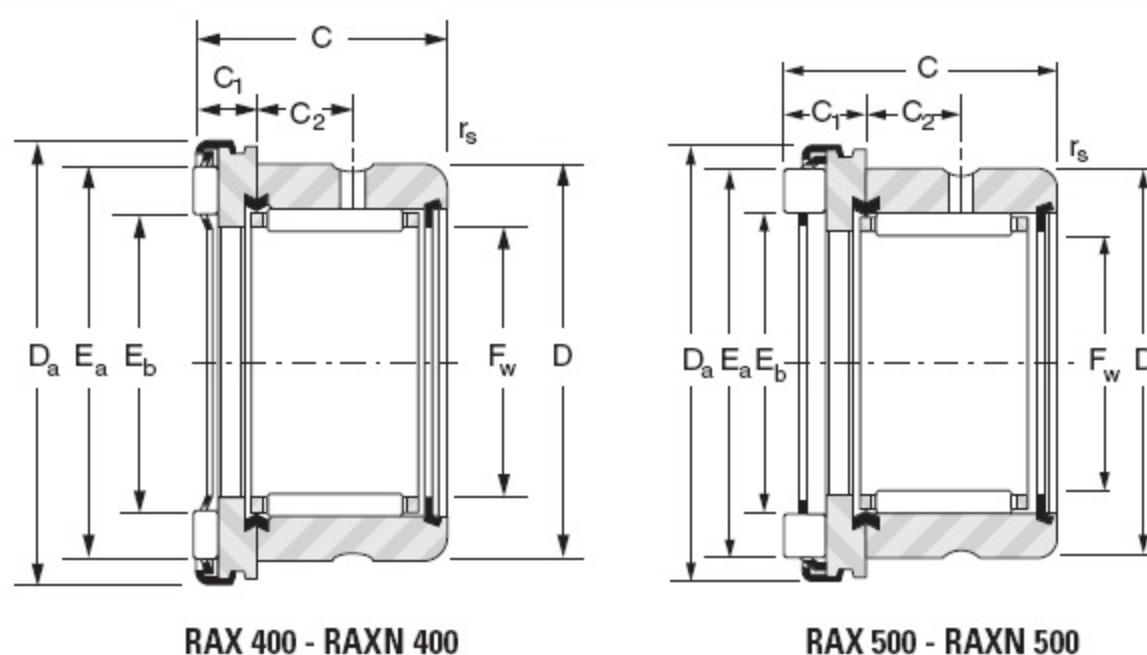

RAX 400 - RAXN 400

RAX 500 - RAXN 500

Shaft ∅ mm	Designations		F _w mm	C mm	D mm	D _a mm	E _b mm	E _a mm	C ₁ mm	C ₂ mm	r _s min mm
	RAX 400 series	RAX 500 series									
10	RAX 410		10	19	19	22	12	18.6	5	6	0.35
		RAX 510	10	19.5	19	22	12.2	18.5	5.5	6	0.35
12	RAX 412		12	19	21	26	15	22.6	5	6	0.35
		RAX 512	12	20	21	26	22.9	14.8	6	6	0.35
15	RAX 415		15	19	24	28	17	24.6	5	6	0.35
		RAX 515	15	20	24	28	16.8	24.9	6	6	0.35
17	RAX 417		17	21	26	30	19	26.6	5	8	0.65
		RAX 517	17	22	26	30	18.8	26.9	6	8	0.65
20	RAX 420		20	24	30	35	22	31.6	6	9	0.85
		RAX 520	20	26	30	35	22	31.6	8	9	0.85
25	RAX 425		25	24	37	42	27.7	37.4	6	9	0.85
		RAX 525	25	26	37	42	27.7	37.4	8	9	0.85
30	RAX 430		30	24	42	47	32.7	42.4	6	9	0.85
		RAX 530	30	26	42	47	32.7	42.3	8	9	0.85
35	RAX 435		35	24	47	53	37.2	49	6	9	0.85
		RAX 535	35	27	47	53.4	37.8	47.8	9	9	0.85
40	RAX 440		40	24	52	60	43	54.9	6	9	0.85
		RAX 540	40	28	52	60.4	54.8	42.8	10	9	0.85
45	RAX 445		45	24	58	65	48	59.9	6	9	0.85
		RAX 545	45	28	58	65.4	47.8	59.8	10	9	0.85
50	RAX 450		50	27	62	70	53.3	65.7	6	11	1.3
		RAX 550	50	31	62	70.4	52.8	64.8	10	11	1.3
60	RAX 460		60	28	72	85	63.5	79.2	7	11	1.3
		RAX 560	60	32	72	85.4	63.5	79.5	11	11	1.3
70	RAX 470		70	28	85	95	73.5	89.2	7	11	1.3
		RAX 570	70	32	85	95.4	73.5	89.5	11	11	1.3