



# VCM & VCB SERIES MALE ROD ENDS

General Purpose - Economy - Self-Lubricating

www.aurorabearing.com • Fax 630-859-0971



**Body** - Low carbon steel, protective coated for corrosion resistance.

**Ball** - Alloy steel, heat treated, hard chrome plated.

**Bushing** - Steel Backed, PTFE Composite

**Notes** - All sizes available with studs upon request.

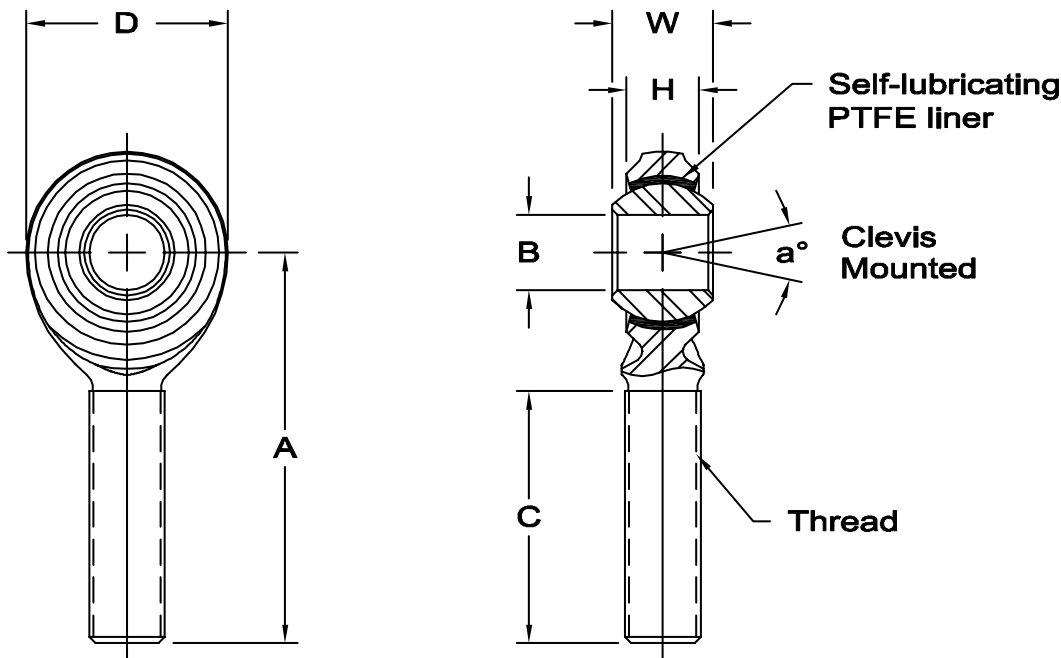

ROD END NO.		DIMENSIONS IN INCHES								a° Misalign. Angle	Ultimate Radial Static Load Capacity Lbs.	Approx. Brg. Wt. Lbs.
Right Hand	Left Hand	B + .0025 - .0005	W ± .005	H Ref.	A ± .015	D Ref.	Ball Dia. Ref.	C + .062 - .031	Thread UNF-3A			
VCM-5	VCB-5	.3125	.437	.312	1.875	.875	.593	1.250	5/16-24	18	2,623	.07
VCM-6	VCB-6	.3750	.500	.359	1.938	1.000	.687	1.250	3/8-24	18	3,643	.11
VCM-7	VCB-7	.4375	.562	.406	2.125	1.125	.781	1.375	7/16-20	17	4,464	.15
VCM-8	VCB-8	.5000	.625	.453	2.438	1.312	.875	1.500	1/2-20	16	7,229	.24
VCM-10	VCB-10	.6250	.750	.484	2.625	1.500	1.062	1.625	5/8-18	22	8,204	.36
VCM-12	VCB-12	.7500	.875	.593	2.875	1.750	1.250	1.750	3/4-16	20	12,280	.57

ROD END NO.		DIMENSIONS IN MILLIMETERS								a° Misalign. Angle	Ultimate Radial Static Load Capacity Newtons	Approx. Brg. Wt. Grams
Right Hand	Left Hand	B + .064 - .013	W ± .13	H Ref.	A ± .38	D Ref.	Ball Dia. Ref.	C + 1.57 - .79	Thread UNF-3A			
VCM-5	VCB-5	7.938	11.10	7.92	47.63	22.23	15.06	31.75	5/16-24	18	11,667	32
VCM-6	VCB-6	9.525	12.70	9.12	49.23	25.40	17.45	31.75	3/8-24	18	16,204	50
VCM-7	VCB-7	11.113	14.27	10.31	53.98	28.58	19.84	34.93	7/16-20	17	19,856	68
VCM-8	VCB-8	12.700	15.88	11.50	61.93	33.32	22.23	38.10	1/2-20	16	32,155	109
VCM-10	VCB-10	15.875	19.05	12.29	66.68	38.10	26.97	41.28	5/8-18	22	36,491	163
VCM-12	VCB-12	19.050	22.23	15.06	73.03	44.45	31.75	44.45	3/4-16	20	54,621	259